

Kommode Adele 2D

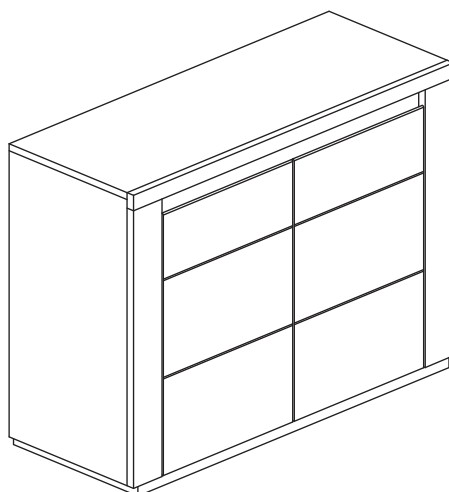

<ul style="list-style-type: none">• Zalecamy nie wyrzucać opakowania dopóki nie ukończysz montażu.• Montażu najlepiej dokonać na miękkiej i czystej powierzchni, takiej jak tektura, ręcznik, koc. Uchroni to przed uszkodzeniem mebla.• Zarówno opakowania plastikowe, jak i okucia trzymać w miejscu niedostępnym dla niemowląt i dzieci.• Wszystkie połączenia powinny być odpowiednio dokręcone.• Przed przystąpieniem do montażu prosimy zapoznać się z całą instrukcją montażu. Zestaw montażowy znajduje się w opakowaniach. Prosimy dokładnie sprawdzić każdą paczkę.• Przed przystąpieniem do montażu prosimy sprawdzić czy nie brakuje żadnych elementów.	
<ul style="list-style-type: none">• We recommend not discarding the packaging until you have completed the assembly.• It is best to perform the assembly on a soft and clean surface, such as cardboard, a towel, or a blanket. This will protect the furniture from damage.• Keep both plastic packaging and fittings out of reach of infants and children.• All connections should be properly tightened.• Please familiarize yourself with the entire assembly instructions before starting the assembly.• The assembly kit is located in the packaging. Please thoroughly check each package.• Before starting the assembly, please check if any elements are missing.	
<ul style="list-style-type: none">• Wir empfehlen, die Verpackung nicht zu entsorgen, bis Sie die Montage abgeschlossen haben.• Die Montage erfolgt am besten auf einer weichen und sauberen Oberfläche wie Karton, einem Handtuch oder einer Decke. Dadurch wird das Möbel vor Beschädigungen geschützt.• Halten Sie sowohl Kunststoffverpackungen als auch Beschläge außerhalb der Reichweite von Säuglingen und Kindern.• Alle Verbindungen sollten ordnungsgemäß festgezogen werden.• Bitte lesen Sie vor Beginn der Montage die gesamte Montageanleitung.• Das Montageset befindet sich in den Verpackungen. Bitte überprüfen Sie jede Packung sorgfältig.• Bevor Sie mit der Montage beginnen, überprüfen Sie bitte, ob keine Elemente fehlen.	
<ul style="list-style-type: none">• Doporučujeme nevyhazovat obal, dokud nedokončíte montáž.• Montáž je nejlépe provést na měkkém a čistém povrchu, jako je karton, ručník nebo deka. Tím se zabrání poškození nábytku.• Plastové obaly i kování uchovávejte mimo dosah kojenců a dětí.• Všechny spoje by měly být správně utaženy.• Před zahájením montáže si prosím přečtete celý montážní návod.• Montážní sada se nachází v obalech. Prosím pečlivě zkontrolujte každý balíček.• Před zahájením montáže si prosím ověřte, zda nechýbí žádné prvky.	
<ul style="list-style-type: none">• Odporučame neprehadzovať obal, kým nedokončíte montáž.• Montáž je najlepšie vykonať na mäkkom a čistom povrchu, ako je kartón, uterák alebo deka. Tým sa predíde poškodeniu nábytku.• Plastové obaly aj kovania uchovávajú mimo dosahu dočítať a detí.• Všetky spoje by mali byť správne dotiahnuté.• Pred začatím montáže sa prosím oboznámte s celým montážnym návodom.• Montážny set sa nachádza v obaloch. Prosím dôkladne skontrolujte každý balík.• Pred začatím montáže prosím skontrolujte, či nechýbajú žiadne časti.	
<ul style="list-style-type: none">• Vă recomandăm să nu aruncați ambalajul până când nu ați terminat asamblarea.• Este mai bine să asamblați pe o suprafață moale și curată, cum ar fi carton, un prosop sau o pătură. Acest lucru va proteja mobilierul de deteriorare.• Păstrați atât ambalajele din plastic, cât și elementele de fixare în afara accesului copiilor și sugarilor.• Toate conexiunile trebuie să fie strâns corectpunzător.• Vă rugăm să vă familiarizați cu întreaga instrucțiune de asamblare înainte de a începe asamblarea.• Setul de asamblare se află în ambalaje. Vă rugăm să verificați cu atenție fiecare pachet.• Înainte de a începe asamblarea, vă rugăm să verificați dacă nu lipsesc elemente.	

ⓓ Montageanleitung

ⓃL Handleiding voor de montage

ⒸZ Montážní řávod







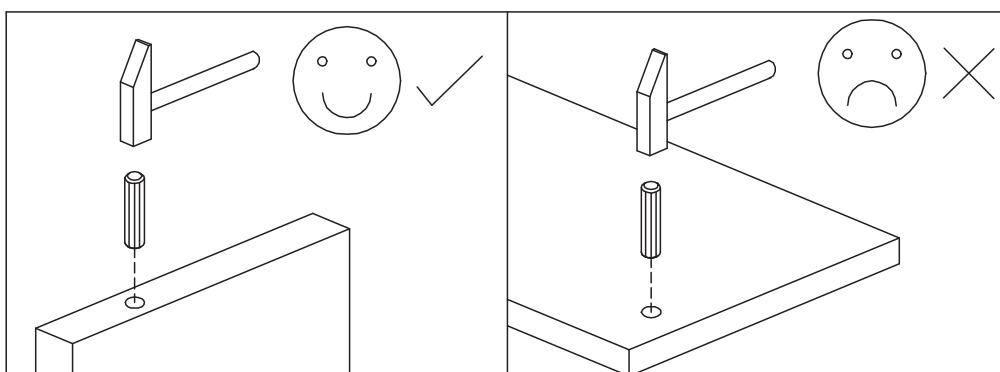
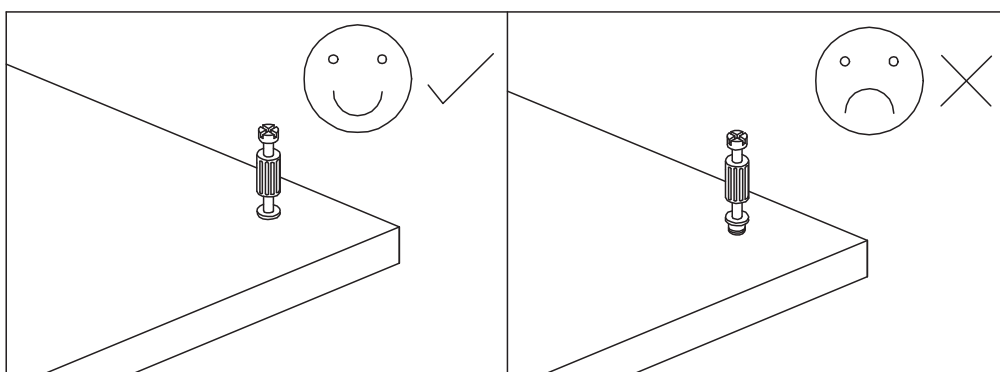
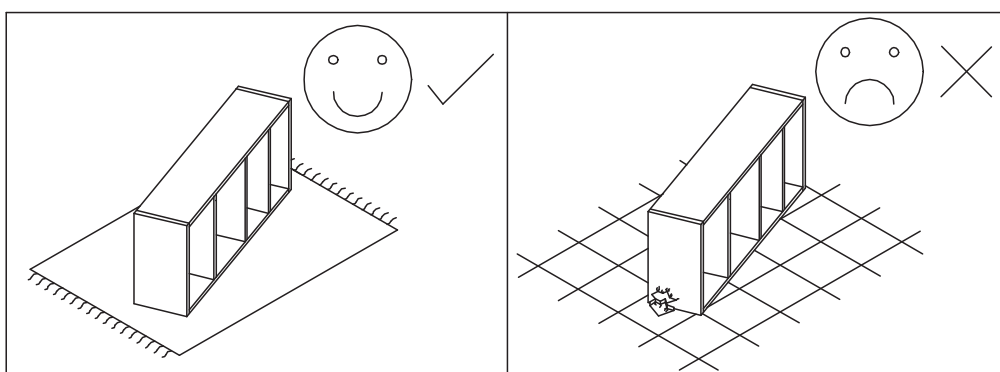
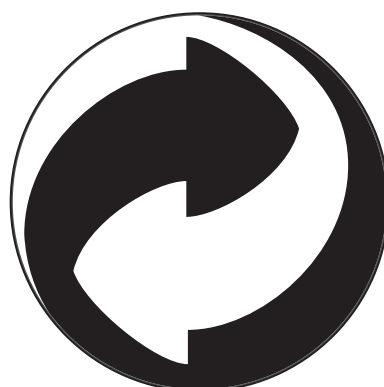
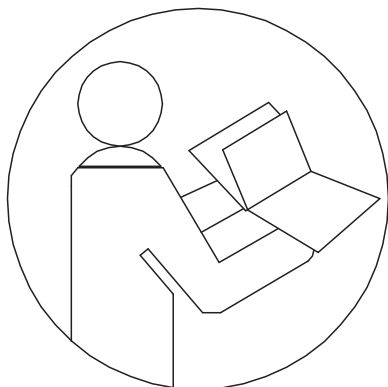

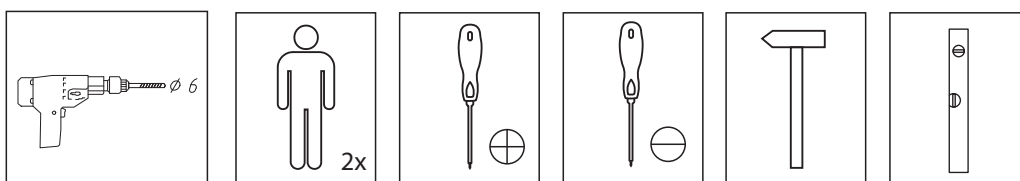
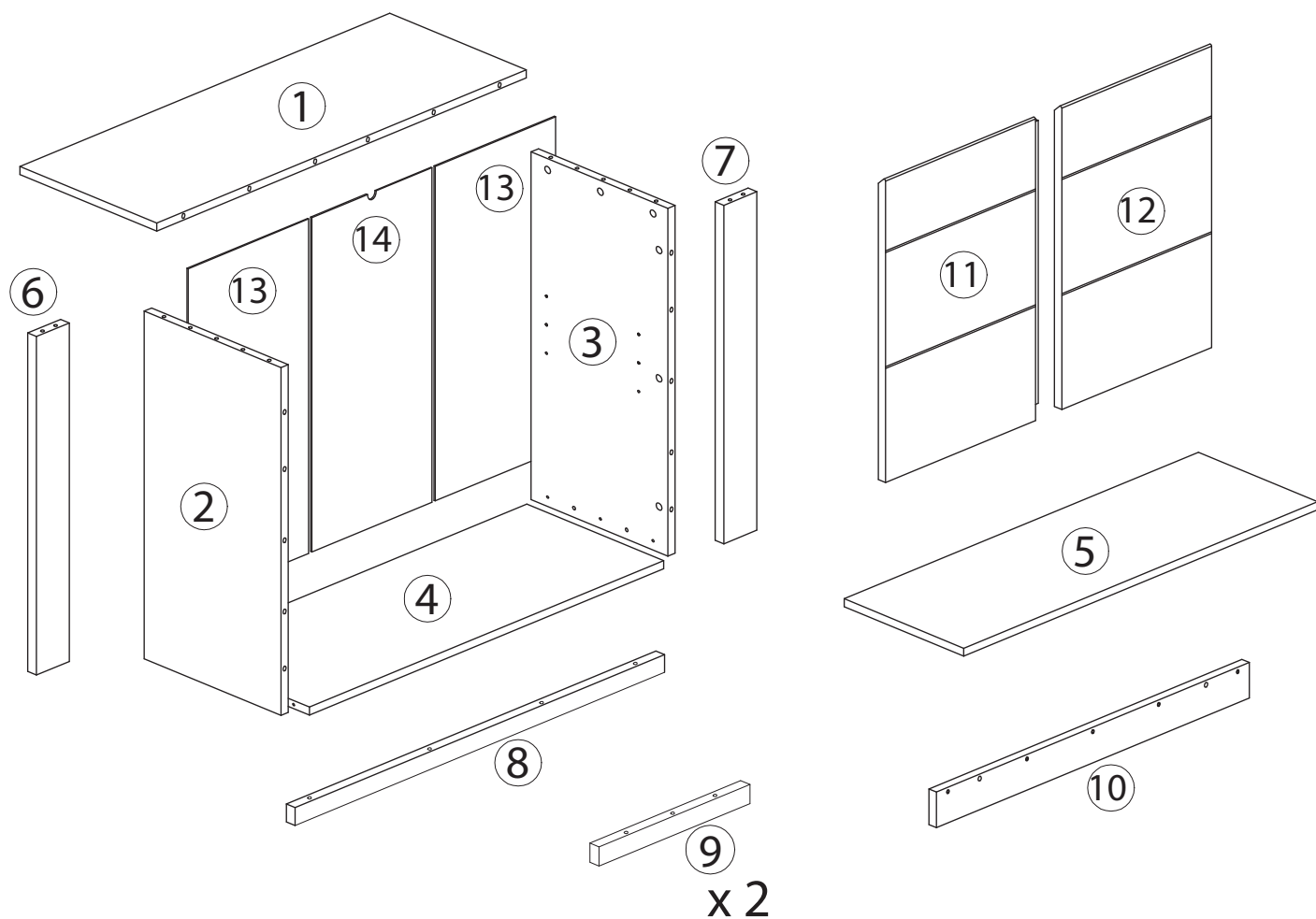

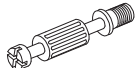
ⓇO Instrucțiuni de montaj

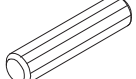
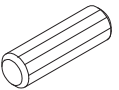
ⓅL Instrukcja montażu

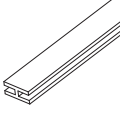
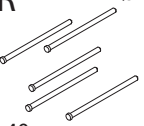
ⓈK Návod na mŏňtaz

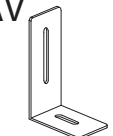
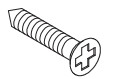
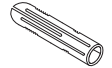

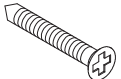

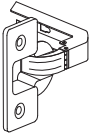
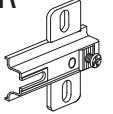
A  x 21	B  x 21	C  x 16	D Ø8x30  x 14	D2 Ø8x20  x 2	E  x 4	J  x 2	R Ø1  x 40	AB Ø3,5x16  x 8
AV  x 1	BO Ø4x25  x 5	BW Ø6x30  x 1	CB Ø6,3x13  x 8	CP Ø4x16  x 1	DB Ø4x40  x 11	FG  x 6	FS  x 4	ZJ  x 4
ZR  x 4								

1

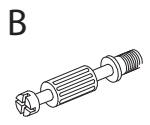
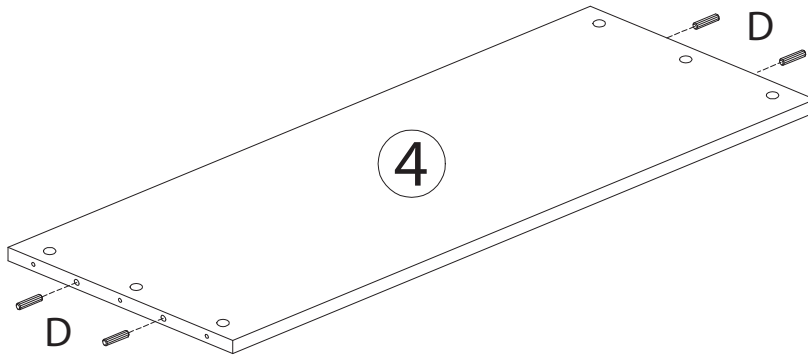
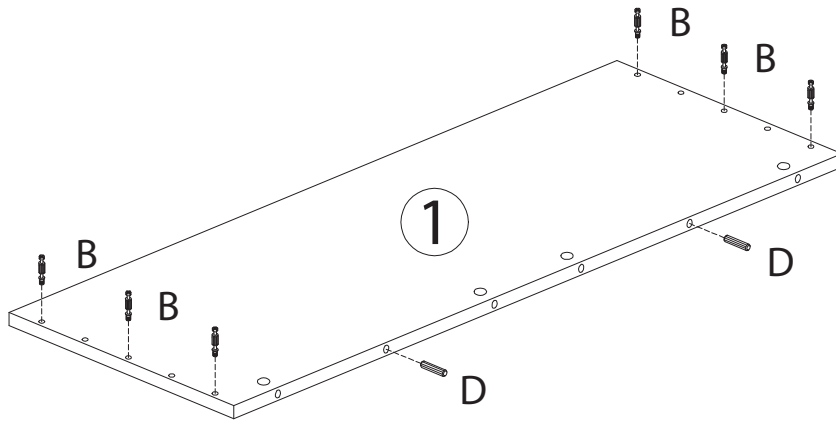
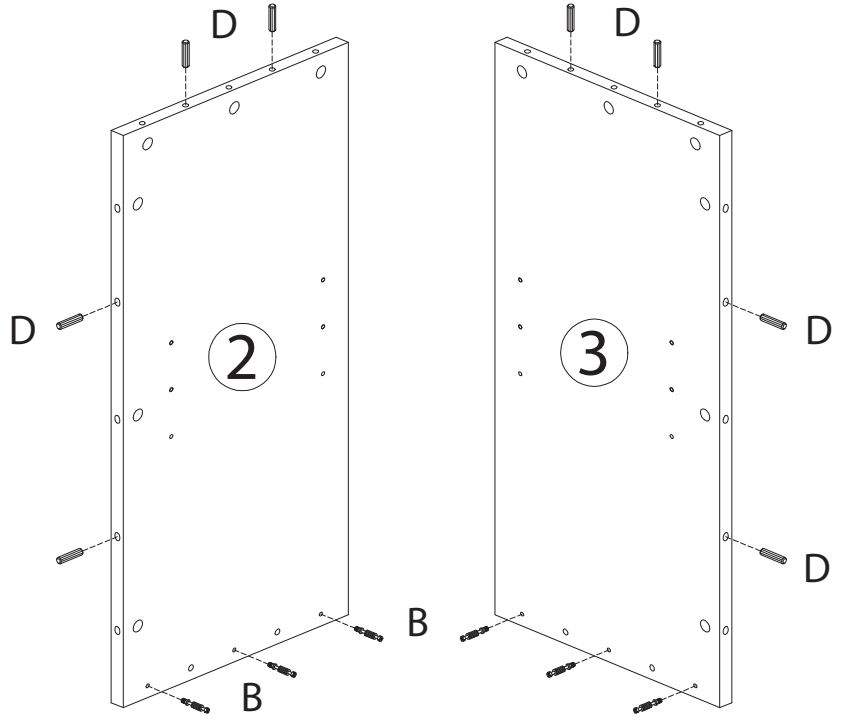
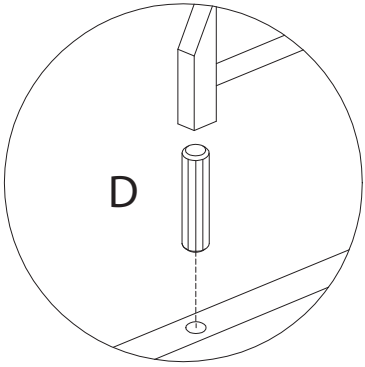
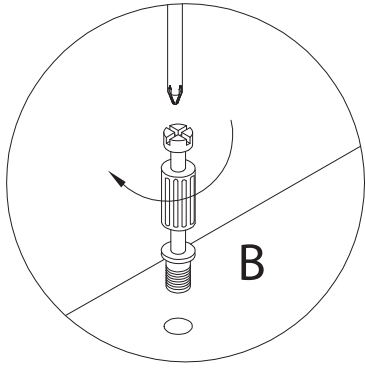

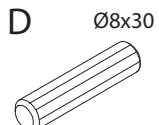

x 12

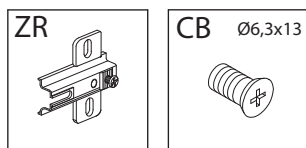
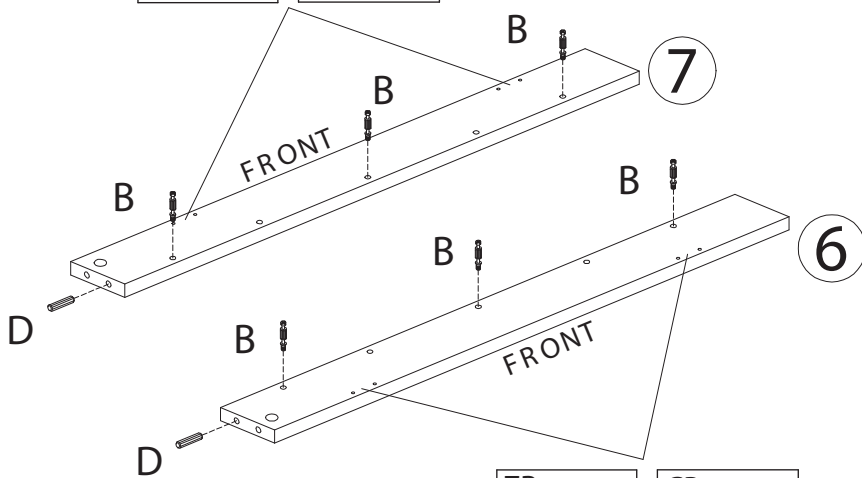
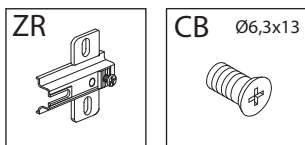
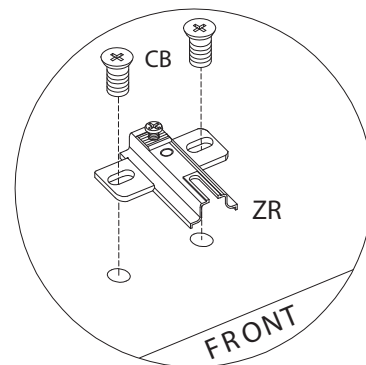
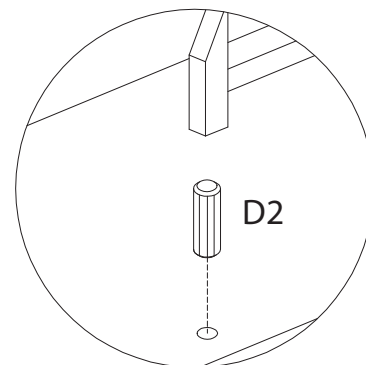
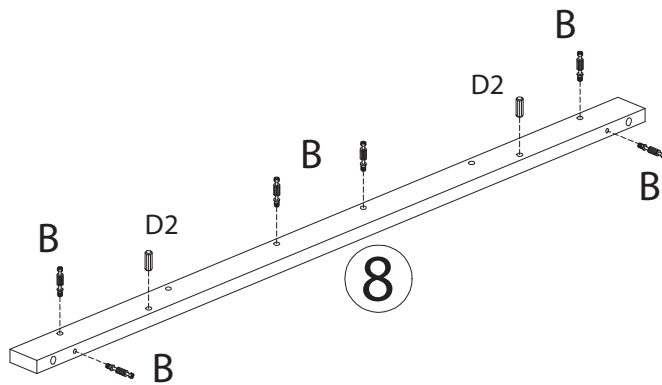

x 14

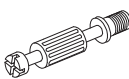
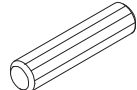
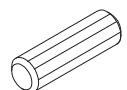

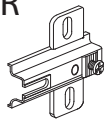
<p>B</p>  <p>x 12</p>	<p>D Ø8x30</p>  <p>x 2</p>	<p>D2 Ø8x20</p>  <p>x 2</p>	<p>CB Ø6,3x13</p>  <p>x 8</p>	<p>ZR</p>  <p>x 4</p>
--	---	--	--	---

3

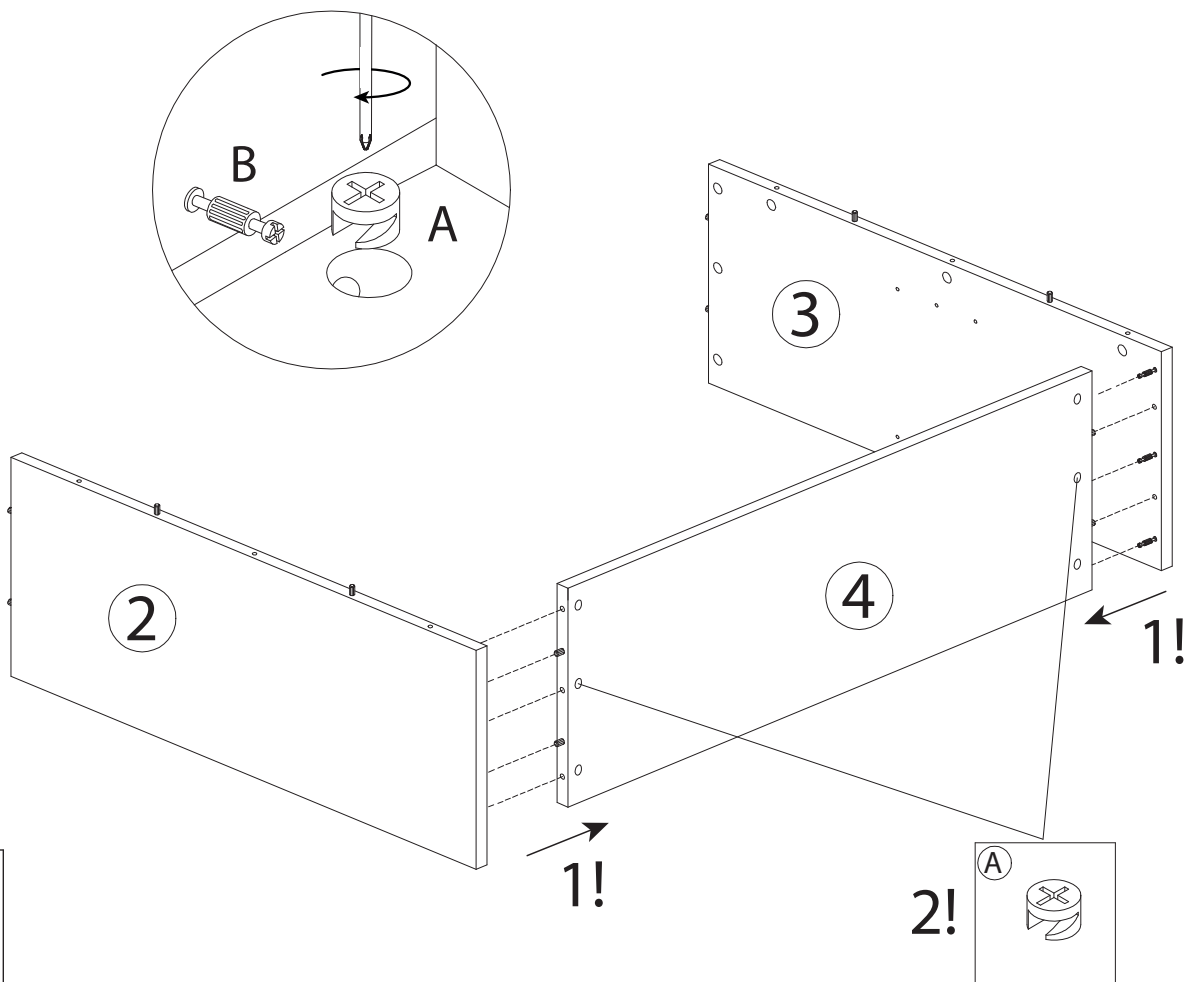

A



x 6

4

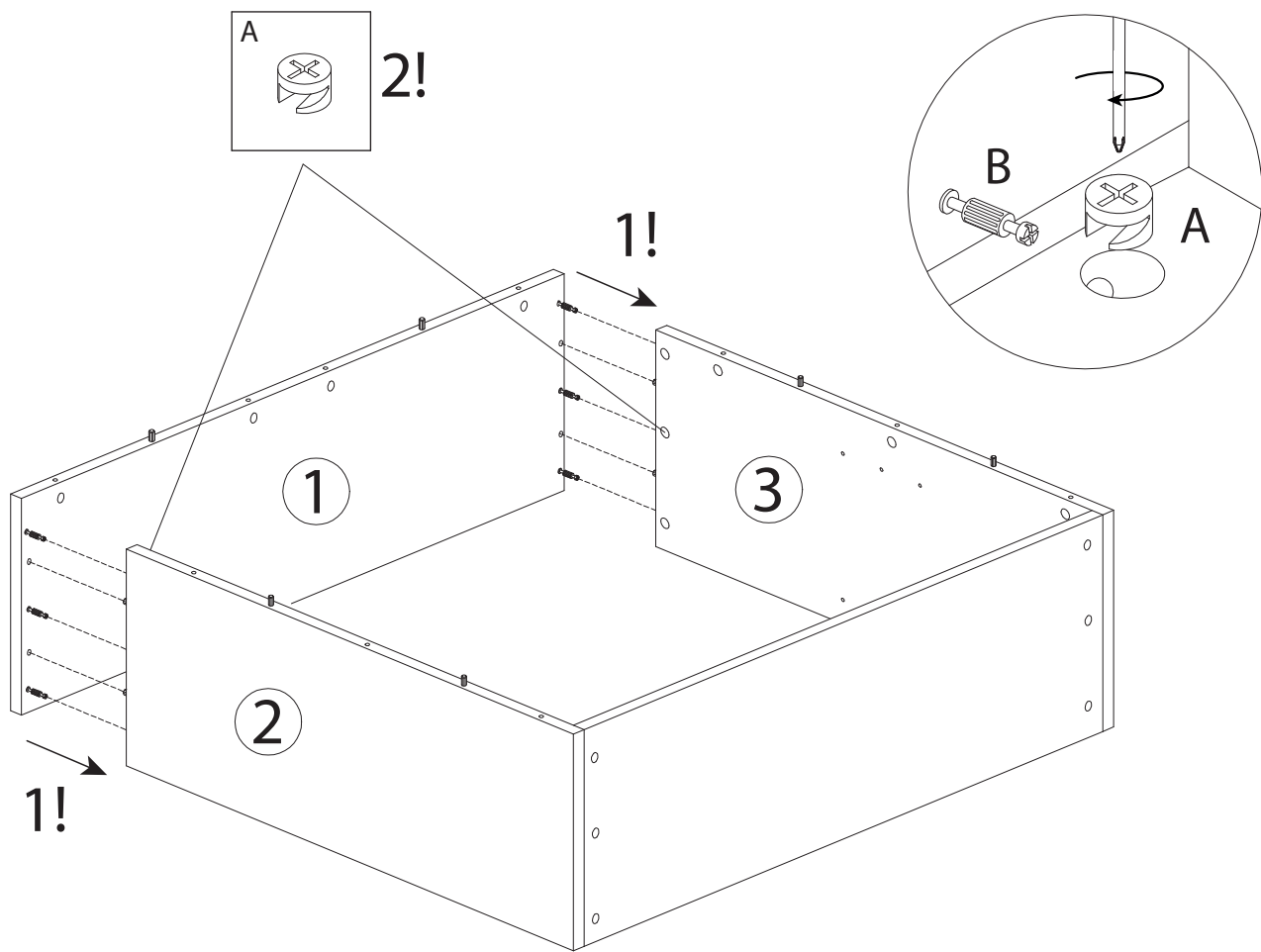

A



2!

A



x 6

5

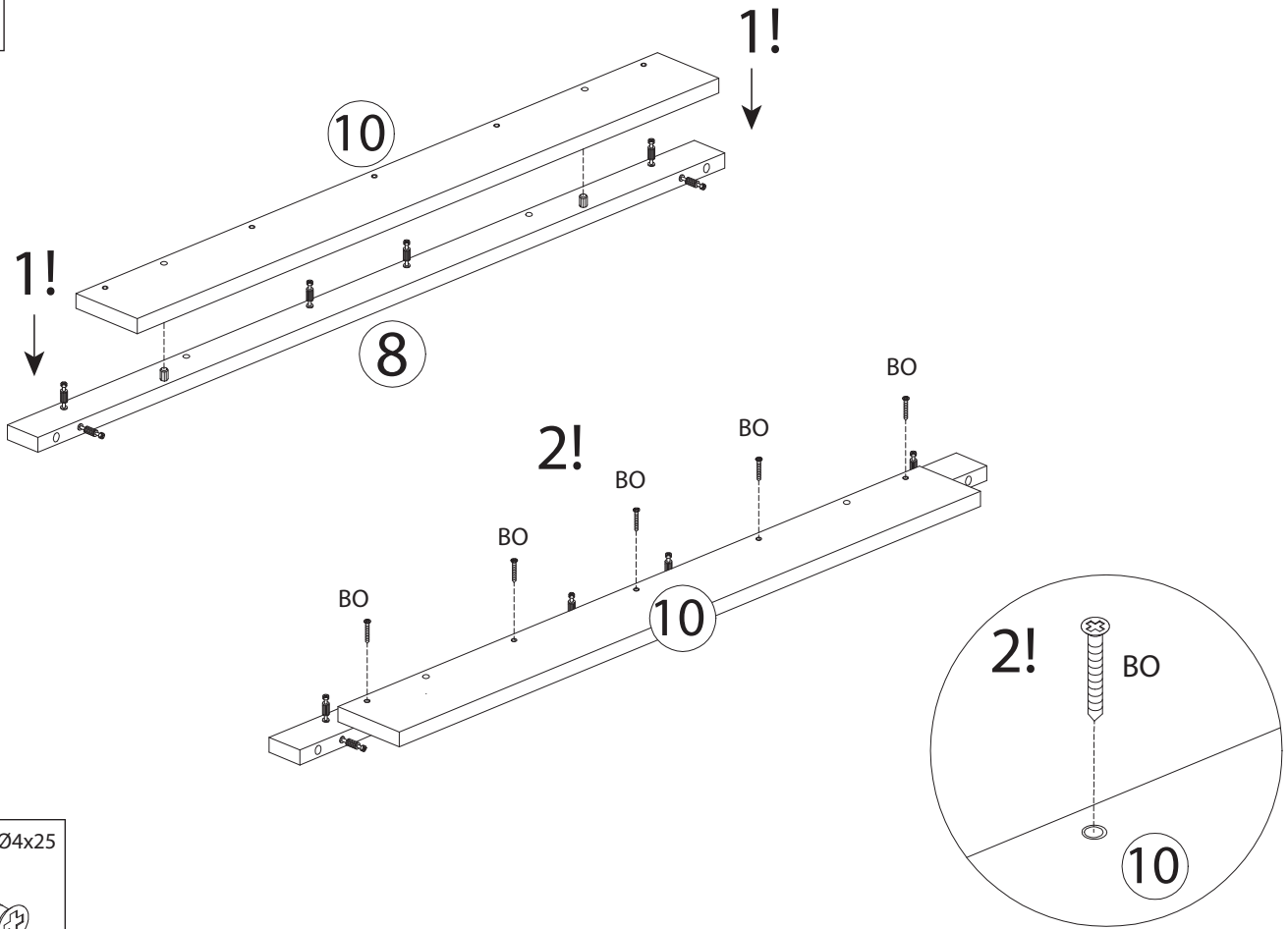

BO Ø4x25

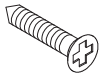

x 5

6

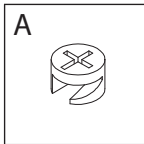
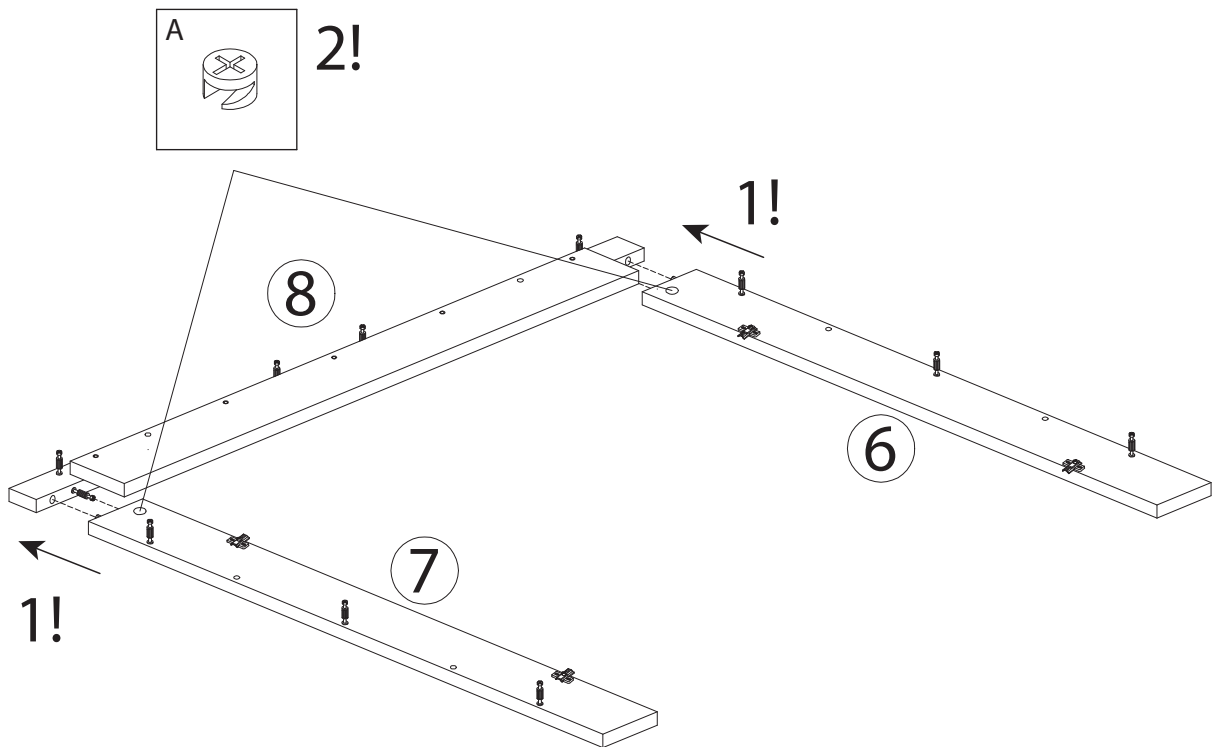

2!

A



x 2

7

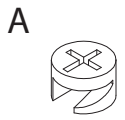
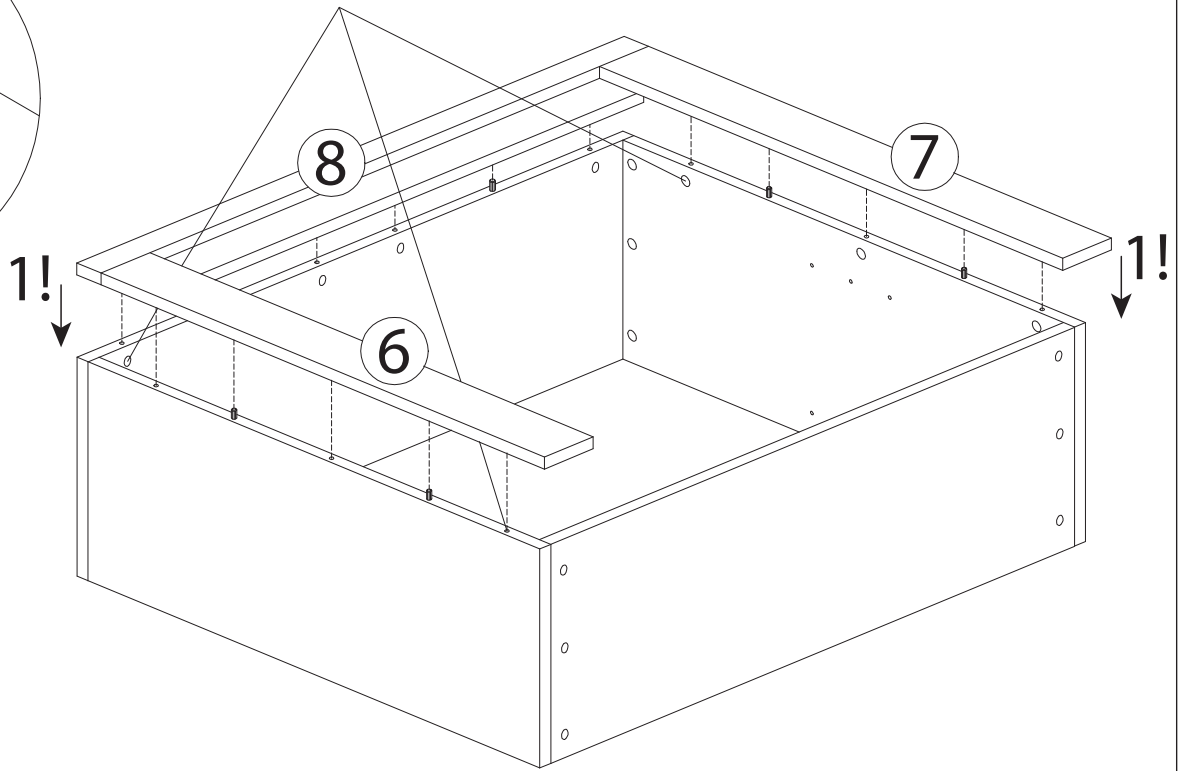
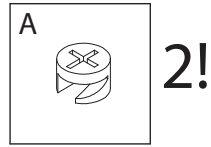
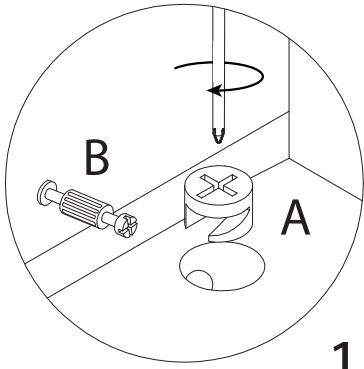

x 10

8

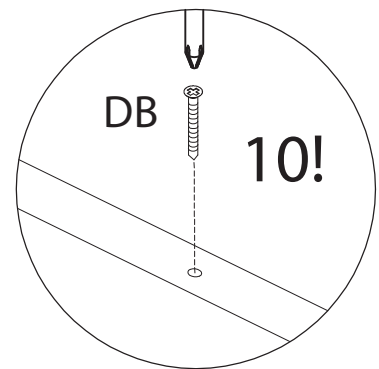
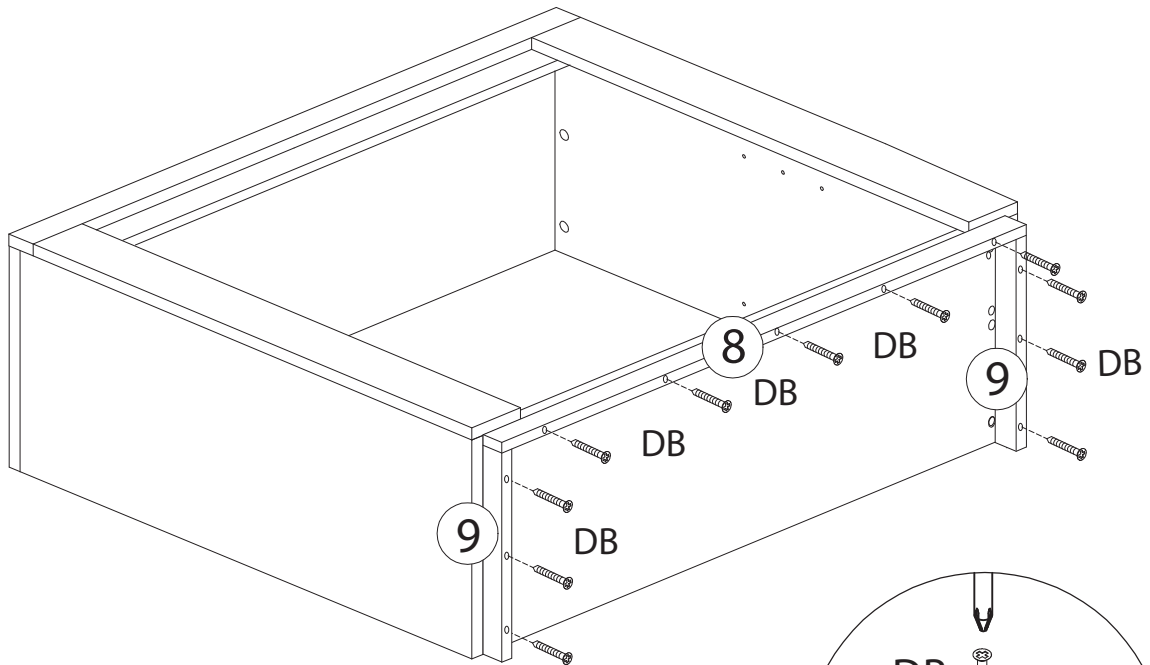

DB Ø4x40

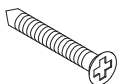

x 10

9

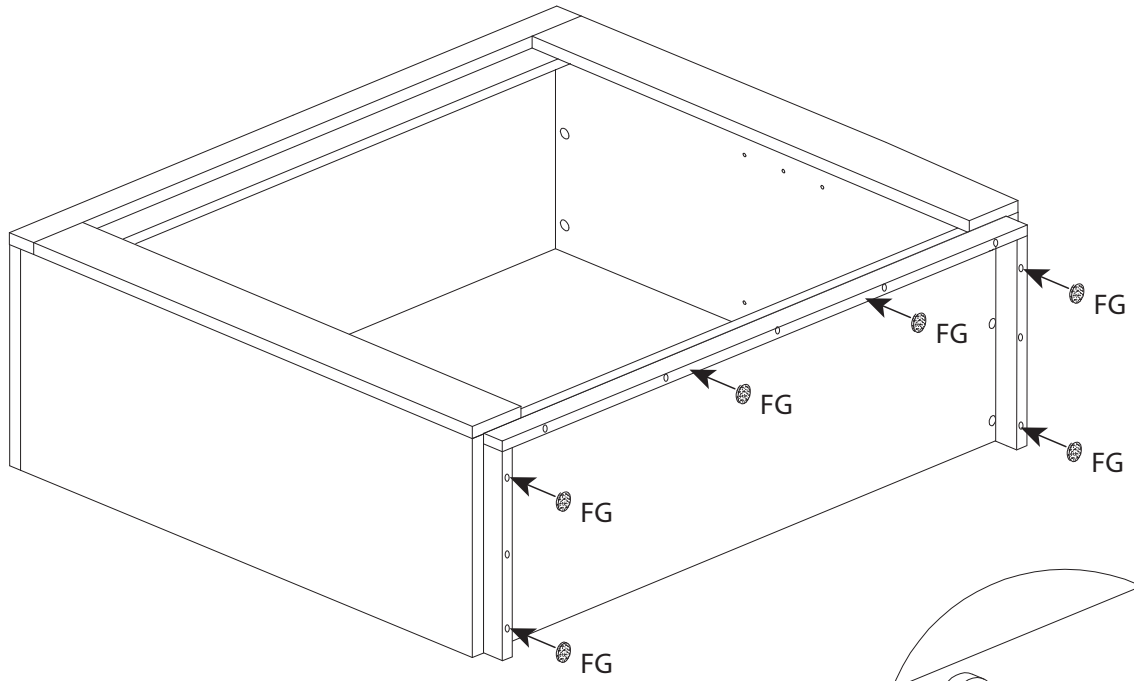

x 6

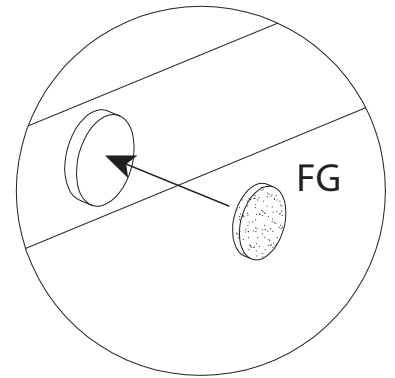

FG



x 6

10

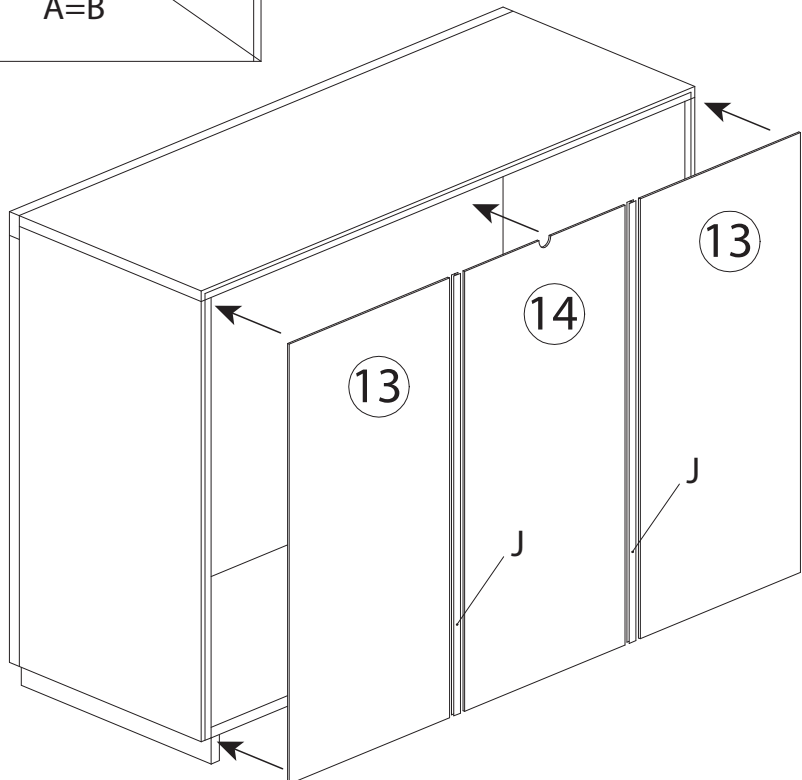
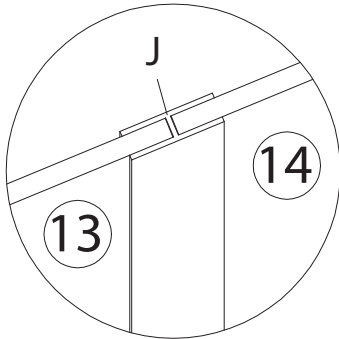
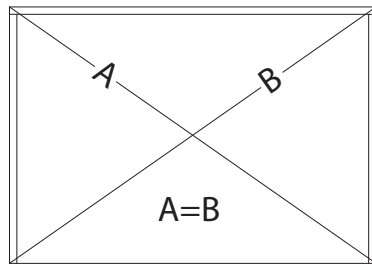
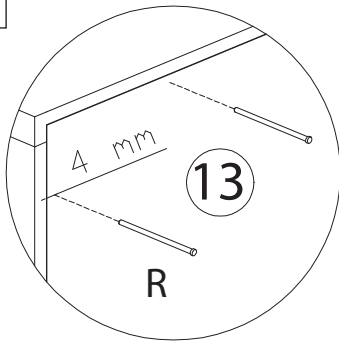

J

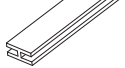

x 2

R

Ø1



x 40

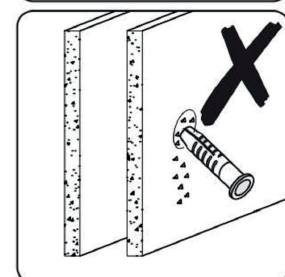
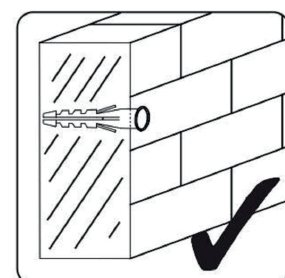
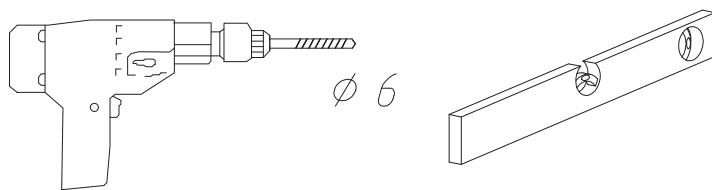
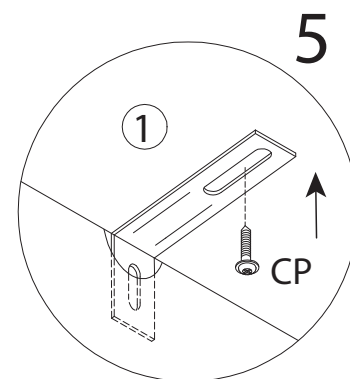
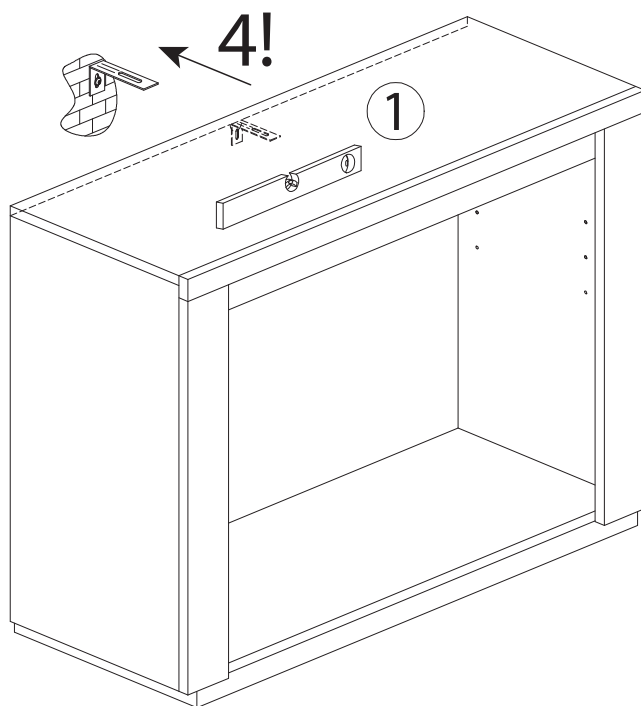
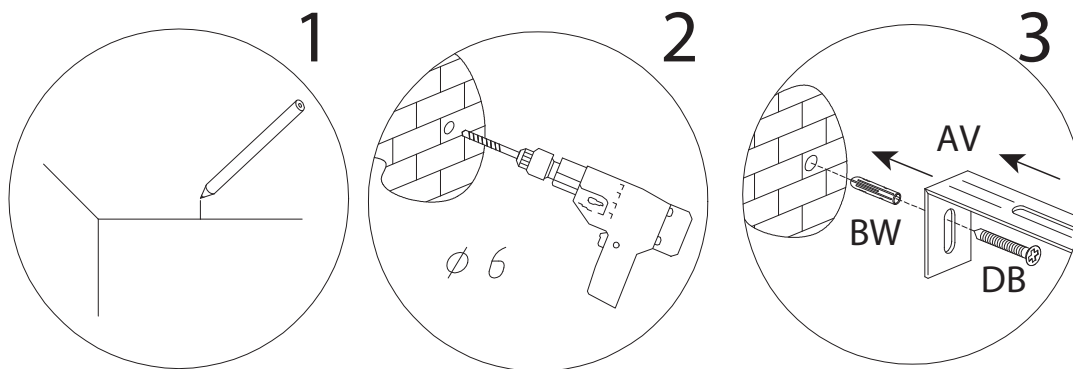

AV x 1	BW Ø6x30 x 1	CP Ø4x16 x 1	DB x 1
------------------	------------------------	------------------------	------------------

•Uwaga •Achtung •Attention •Caution •Fig •Attenzione •Atentie •Upozornění •Upozornění		
(D)	Die Wandmontage darf nur von Fachpersonal durchgeführt werden, da bei der Wandmontage geeignete Dübel verwendet werden müssen.	
(NL)	De wandmontage mag uitsluitend door gekwalificeerd personeel worden uitgevoerd. Bij de wandmontage moeten geschikte pluggen worden gebruikt.	
(CZ)	Montáž na stěnu smí provádět pouze kvalifikovaný personál, protože při montáži na stěnu je nutné použít vhodné hmoždinky.	
(RO)	Montarea pe perete poate fi efectuată numai de către personal calificat, deoarece la montarea pe perete trebuie utilizate dibluri adecvate.	
(PL)	Mocowanie do ściany może przeprowadzić wyłącznie odpowiedni do tego personel, ponieważ w czasie montażu w ścianie konieczne jest zastosowanie dopasowanych kołków.	
(SK)	Montáž na stenu smie vykonávať iba kvalifikovaný personál, pretože pri montáži na stenu sa musia použiť vhodné hmoždinky.	

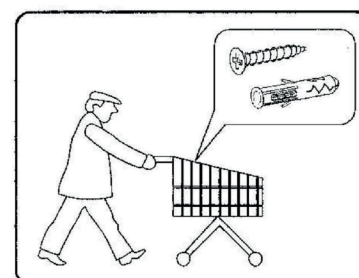

13

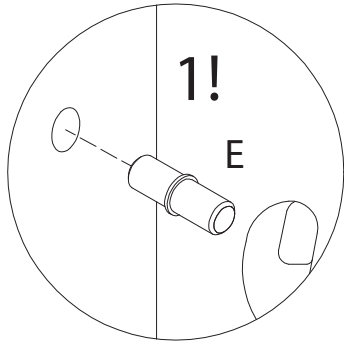
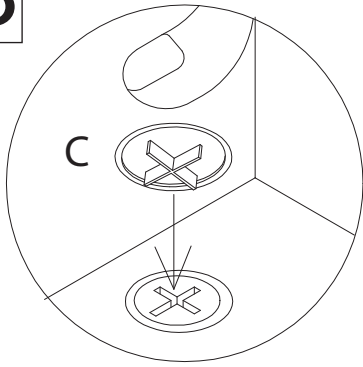

1!

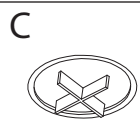
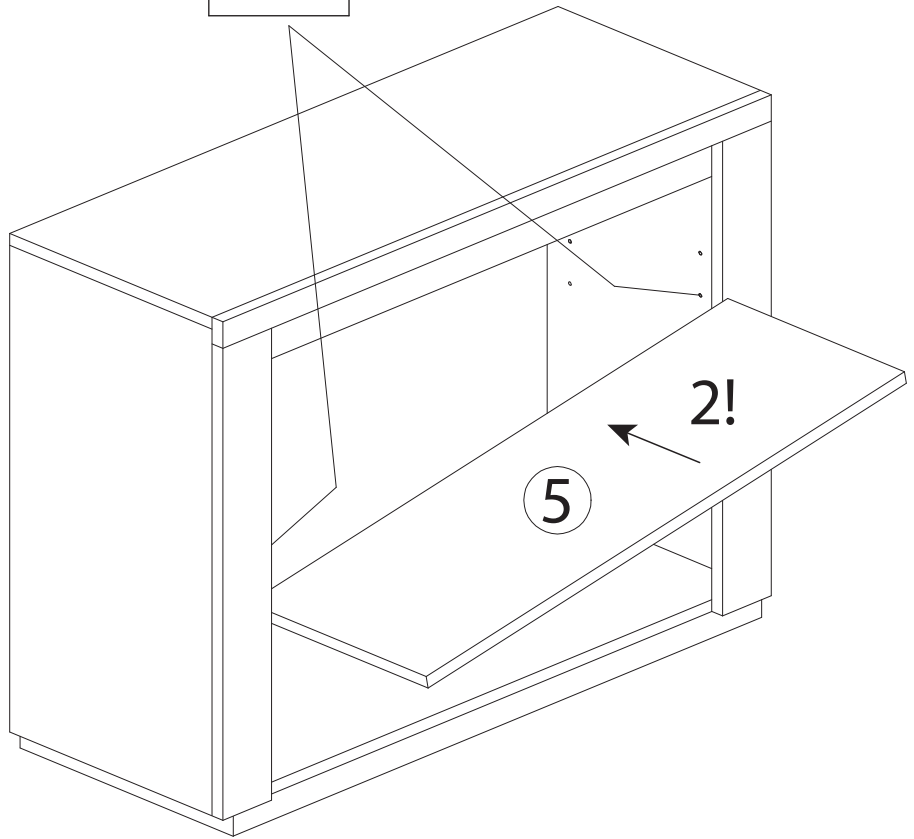
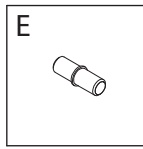

x 16

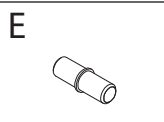

x 4

14

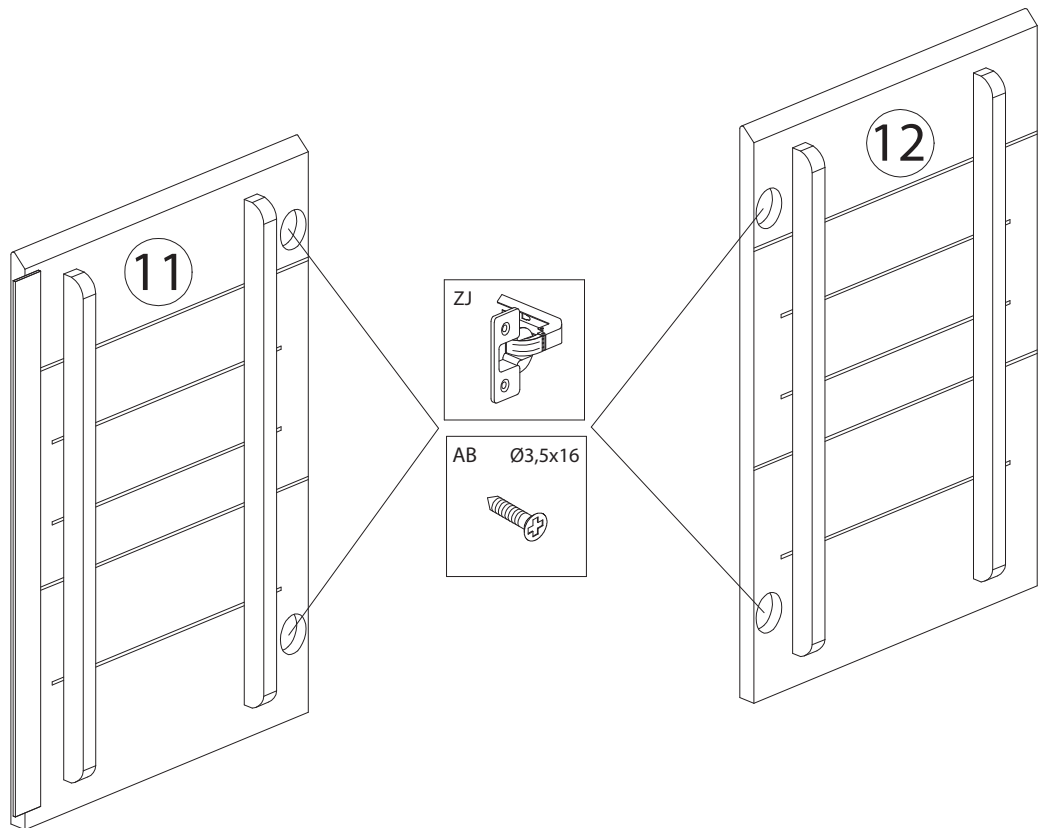
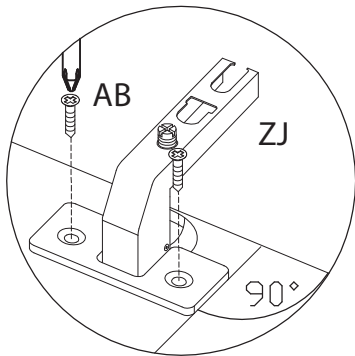

AB Ø3,5x16

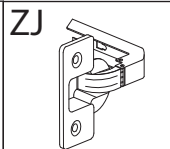

x 8

x 4

15

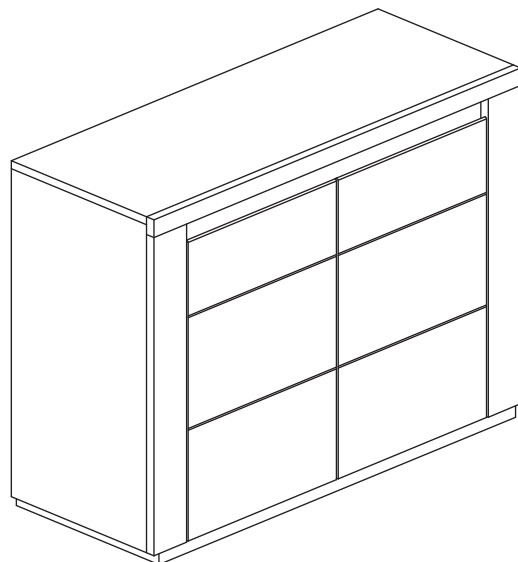
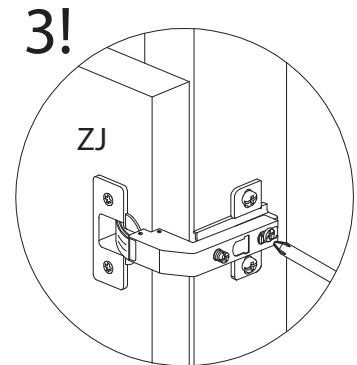
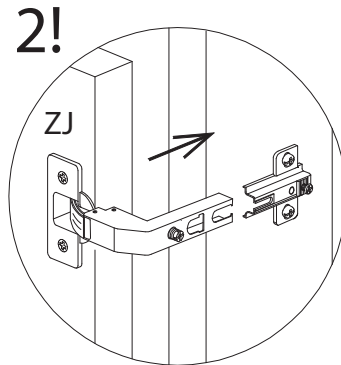
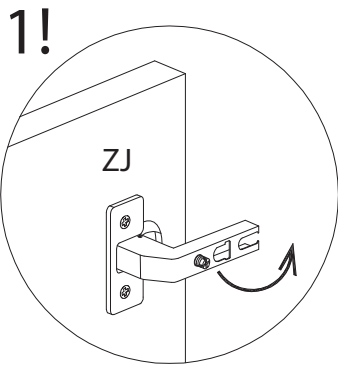
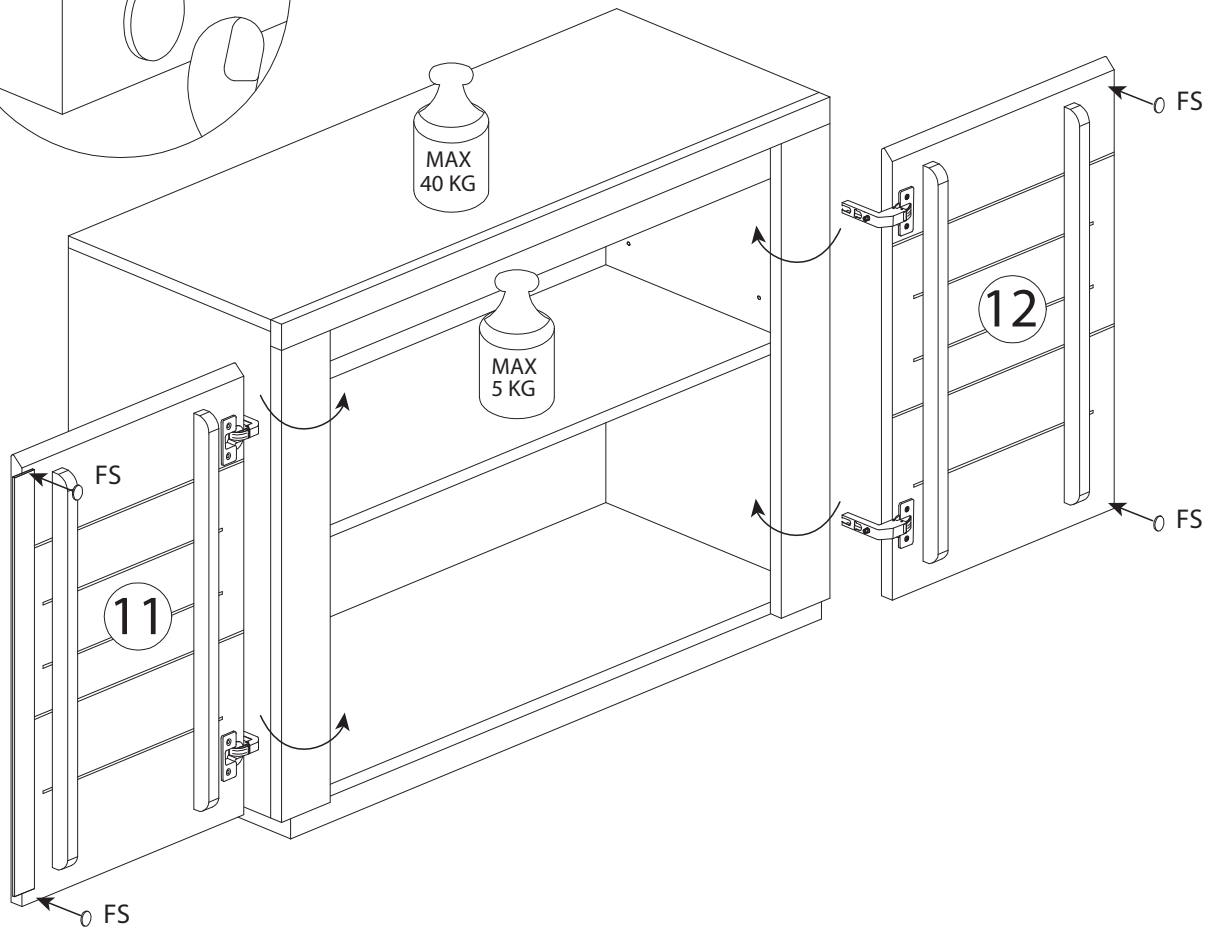
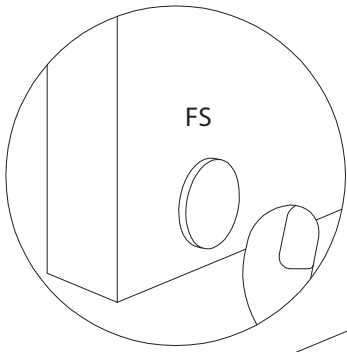

FS



x 4

(D) Turen einstellen (Scharniere justieren)

(PL) Nastawic drzwi (wyrównac zawiasy)

(RO) Ajustați ușa (aliniați balamalele)

(CZ) Seřid ťe dveře (vyrovnajte závěsy)

(NL) Deuren instellen (scharnieren afstellen)

(SK) Zrad ťe dvere (vyrovnajte zavesy)

ZJ

∅ 35

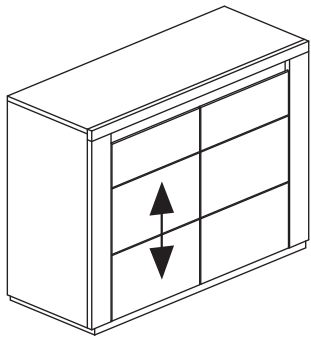
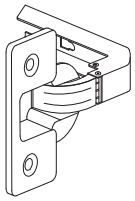

1!

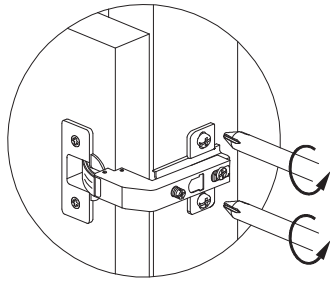

2!

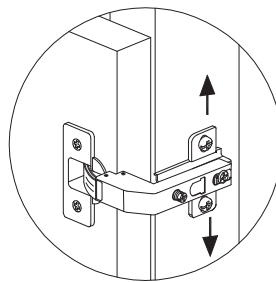

3!

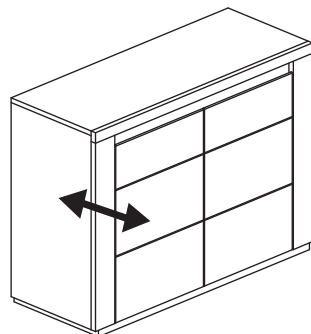
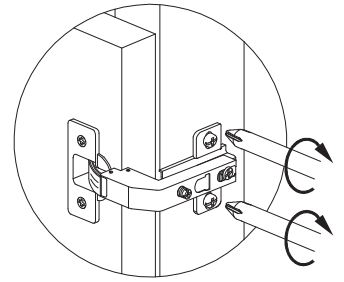

1!

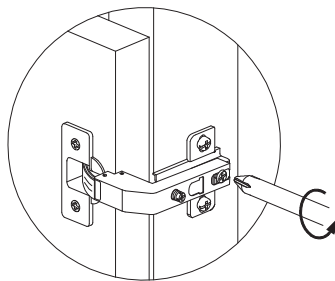

2!

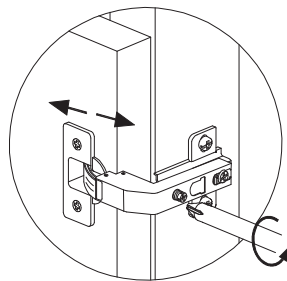

3!

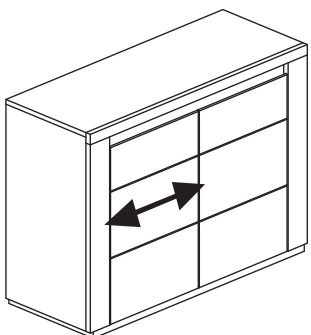
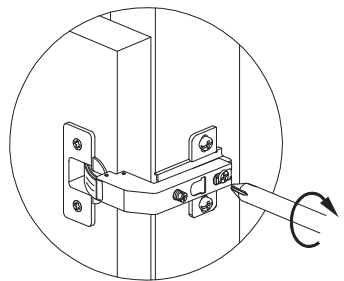

1!

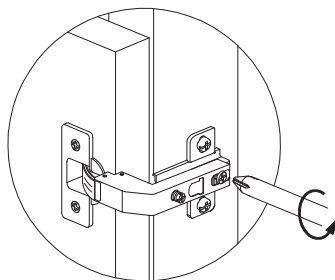

2!

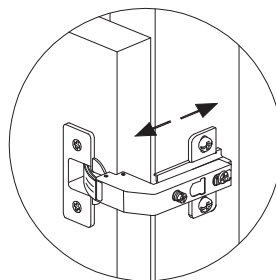

3!

